

A Radio Spectrum Measurement Platform for Spectrum Surveying in Cognitive Radio

Miguel López-Benítez and Fernando Casadevall

Department of Signal Theory and Communications
Universitat Politècnica de Catalunya
Barcelona, Spain
{miguel.lopez,ferranc}@tsc.upc.edu

Abstract. This paper presents a sophisticated radio spectrum measurement platform specifically envisaged and designed for spectrum occupancy surveys in the context of Dynamic Spectrum Access/Cognitive Radio (DSA/CR). The presented tool is a very flexible computer-controlled radio measurement system, which has successfully been used in extensive spectrum measurement campaigns and empirical studies in the context of the DSA/CR technology. An exhaustive and in-depth description of the developed measurement platform is provided, with a special emphasis on implementation details and lessons learned during the development of the tool that may result helpful to other researchers and engineers in the development of similar radio spectrum measurement tools.

Key words: dynamic spectrum access, cognitive radio, spectrum survey, measurement platform

1 Introduction

The measurement of real network activities constitutes an important mean towards a realistic understanding of spectrum use. By means of field measurements of the radio environment, regulatory agencies have been gathering frequency usage data for spectrum management purposes since several decades ago [1]. Spectrum measurements are essential for a proper understanding of real spectrum usage and can support regulatory organisms in taking actions to improve the use of the precious spectral resources. A good example of this is the important number of recent spectrum measurement campaigns that have been carried out all over the world in order to determine the degree to which allocated spectrum bands are used in real wireless communication systems [2–14]. Measurement results have demonstrated that spectrum is currently underutilized as a result of the owned spectrum allocation policy in use since the early days of modern radio communications. The conclusions of such studies have served not only to convince regulatory bodies and policy makers on the necessity of new spectrum access policies but also to support them in taking actions to enhance the use of the currently underutilized spectral resources. As a result, new flexible spectrum use paradigms have gained popularity during the last years [15–17]. In

particular, the Dynamic Spectrum Access (DSA) principle [18], relying on the Cognitive Radio (CR) paradigm [19, 20], has recently emerged as a hopeful solution to conciliate the existing conflicts between spectrum demand growth and spectrum underutilization.

In this context, this work presents a sophisticated radio spectrum measurement platform that has explicitly been designed for spectrum surveys and studies in the context of DSA/CR. The developed platform constitutes a very flexible measurement tool combining a powerful Radio Frequency (RF) measurement system with intelligent computer control and data processing. This platform has successfully been employed to conduct extensive spectrum occupancy measurement campaigns [8, 9, 21] and empirical studies [22] in the context of DSA/CR. While some previous works have been based on similar measurement designs, the focus of such works has been on measurement results rather on the description of the employed measurement configuration. By contrast, this paper presents a rigorous and in-depth discussion of the developed measurement platform, emphasizing many interesting implementation details and lessons learned during the development of the tool that may result helpful to other researchers and engineers in the development of similar tools.

2 Measurement Platform Overview

An appropriate measurement setup for DSA/CR spectrum surveys should be able to detect, over a wide range of frequencies, a large number of transmitters of the most diverse nature, from narrow- to wide-band systems and from weak signals received near the noise floor to strong signals that may overload the receiving system. Depending on the purposes of the study carried out, different configurations have been used in previous spectrum measurements ranging from simple setups with a single antenna directly connected to a spectrum analyzer to more sophisticated and complex designs. Different configurations between both extreme points may determine various trade-offs between complexity and measurement capabilities. The presented platform is mainly based on a spectrum analyzer setup where different external devices have been added in order to improve the detection capabilities of the system and hence obtain more reliable and accurate results. A simplified scheme is shown in Figure 1. The design is composed of two broadband discone-type antennas covering the frequency range from 75 to 7000 MHz, a switch to select the desired antenna, several filters to remove undesired signals, a low-noise pre-amplifier to enhance the overall sensitivity and thus the ability to detect weak signals, a high-performance spectrum analyzer to record the spectral activity, and a laptop (not shown in Figure 1) running a tailor-made software that controls the measurement process. All the components integrating the platform can be divided into four modules (see Figure 2), namely the antenna subsystem, the RF subsystem, the capturing subsystem, and the control subsystem, which are detailed in the following sections.

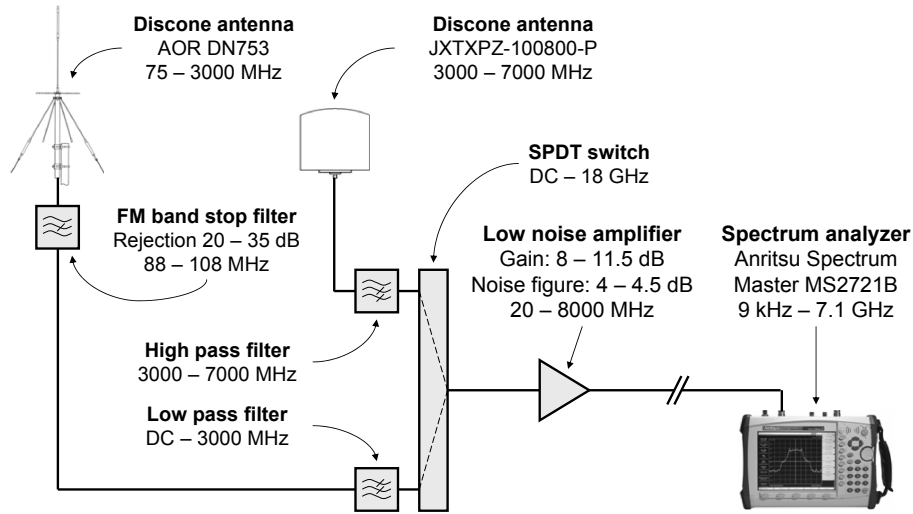

Fig. 1. Simplified scheme of the measurement platform.

3 Antenna Subsystem

When covering small frequency ranges or specific licensed bands a single antenna may suffice. However, in broadband spectrum measurements from a few megahertz up to several gigahertz, two or more broadband antennas are required in order to cover the whole frequency range. The antenna subsystem, shown in Figure 2(a), is composed of two broadband discone-type antennas covering the frequency range from 75 to 7000 MHz. The first antenna (AOR DN753) is used between 75 and 3000 MHz, while the second antenna (A-INFO JTXXPZ-100800/P) covers the frequency range 1–8 GHz but is employed between 3000 and 7000 MHz. Discone antennas are broadband antennas with vertical polarization and omni-directional receiving pattern in the horizontal plane. Even though some transmitters may be horizontally polarized, they usually are high-power stations (e.g., TV stations) that can be detected even with vertically polarized antennas. The exceptionally wide band coverage (allowing a reduced number of antennas in broadband spectrum studies) and the omni-directional feature (allowing the detection of licensed signals coming for any directions) make discone antennas an attractive option in radio scanning and monitoring applications.

4 Radio Frequency Subsystem

The RF subsystem is in charge of performing antenna selection, filtering and amplification. The RF module is shown in Figure 2(b).

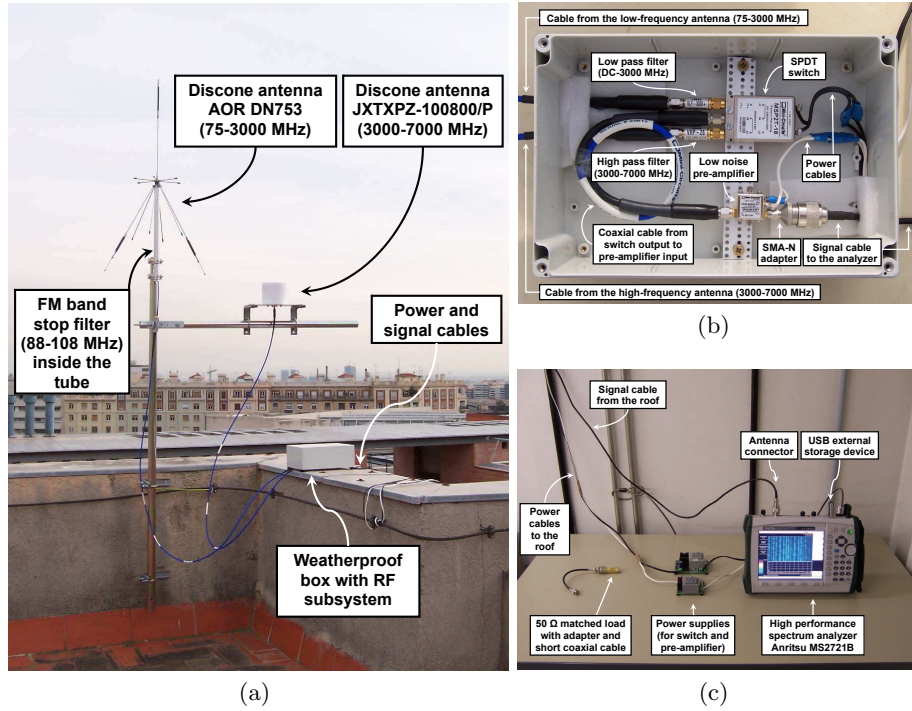

Fig. 2. Modules of the measurement platform: (a) antenna subsystem, (b) RF subsystem, and (c) capturing subsystem. Control subsystem is not shown here.

The desired antenna is selected by means of a Single Pole Double Throw (SPDT) switch. An electromechanical switch (MiniCircuits MSP2T-18) has been selected because of its high isolation (90–100 dB) and low insertion loss (0.1–0.2 dB). When compared to other switch types, electromechanical switches in general provide slower switching times and shorter lifetimes. Nevertheless, this choice results appropriate since antenna switching is always performed off-line by turning the switch on/off between measurement sessions.

To remove undesired signals, three filters are employed. A band stop filter (MiniCircuits NSBP-108+) blocks signals in the frequency range of Frequency Modulation (FM) broadcast stations (87.5–108 MHz). Such stations usually are high power transmitters that may induce overload in the receiver, thus degrading the reception performance with an increased noise floor (which prevents the receiver from detecting the presence of weak signals) or with the appearance of spurious signals (which may be misinterpreted as true signals). Since the FM band is of presumably low interest for opportunistic use due to its usually high transmission powers and occupancy rates, a FM band stop filter is employed in order to remove FM signals and avoid overload problems, improving the detec-

tion of weak signals at other frequencies. Low pass (MiniCircuits VLF-3000+) and high pass (MiniCircuits VHP-26) filters have been used to remove out-of-band signals and reduce the potential apparition of intermodulation products.

To compensate for device and cable losses and increase the system sensitivity, a low-noise pre-amplifier is employed. It is important to note that higher amplification gains result in better sensitivities at the expense of reduced dynamic ranges. Since very different signal levels may be present in broadband spectrum surveys, the existing trade-off between sensitivity and dynamic range must therefore be taken into account. The selected mid-gain amplifier (MiniCircuits ZX60-8008E+) provides significant sensitivity improvements while guaranteeing a Spurious-Free Dynamic Range (SFDR) [23] of 73 dB, which was observed to be enough in practical measurement conditions. Although the employed spectrum analyzer includes a high-gain built-in amplifier, the use of an additional external pre-amplifier closer to the antenna subsystem results in an improved overall noise figure (4-5 dB lower than in the case where only the internal amplifier is employed). For measurements below 3 GHz, where some overloading signals may be present, only the external amplifier is used. For measurements above 3 GHz, where the received powers are lower due to the attenuation of higher frequencies, both the external and the spectrum analyzer's internal amplifier are employed.

5 Capturing Subsystem

A high performance handheld spectrum analyzer (Anritsu Spectrum Master MS2721B) is employed to provide power spectrum measurements and record the spectral activity over the complete frequency range. This spectrum analyzer provides a measurement range from 9 kHz to 7.1 GHz, low noise levels and a built-in pre-amplifier (which facilitates the detection of weak signals), fast sweep speeds automatically adjusted, and various communication interfaces enabling the connection of external USB storage devices as well as controlling instruments. Moreover the handheld, battery-operated design simplifies the displacement of the equipment to different measurement locations.

In spectrum analyzers, a tunable receiver tunes continuously across the selected frequency span, beginning at the lowest frequency of the span and increasing in frequency until the highest frequency of the span is reached. Due to the swept operating principle of spectrum analyzers, the time interval between two consecutive samples of a given frequency channel may be notably high, in the order of several seconds depending on the width of the selected frequency span and the bandwidth of the selected intermediate frequency filter (referred to as *resolution bandwidth*). This means that the effective sampling rate of individual channels cannot be compared to that attained with other capturing devices such as vector signal analyzers or digital sampling cards. Nevertheless, spectrum analyzers have the advantage of providing high sensitivity levels (ability to detect the presence of weak licensed signals), high dynamic ranges (ability to simultaneously detect the presence of signals with very dissimilar power levels) and wide band measurements (ability to observe the occupancy state of all the radio

channels within an entire band), which are fundamental requirements in order to obtain a meaningful and comprehensive picture of spectrum usage.

Since the different configurations and operating modes of spectrum analyzers can significantly alter the results of a measurement, proper parameter selection is crucial to produce valid and meaningful results. Table 1 shows the selected values for the main spectrum analyzer parameters. This configuration has been selected as an adequate trade-off among many interdependent aspects, taking into account not only the basic principles of spectrum analysis [24] but also some particular considerations specific to the context of DSA/CR as exhaustively discussed in [25]. Although the optimum configuration of a spectrum analyzer depends on the particular characteristics of the spectrum band and signal under study, the configuration shown in Table 1 has been proven to provide satisfactory results in practice over a wide range of allocated spectrum bands with heterogeneous characteristics in terms of transmission powers, dynamic ranges and RF bandwidths. A brief explanation of the configuration in Table 1 is provided in the following. A more detailed discussion can be found in [25].

Spectrum analyzers provide the results of a sweep with a finite number of discrete frequency points. In the case of the employed spectrum analyzer, the number of frequency points provided for a given range of frequencies (frequency span) is fixed and equal to 551 points per span. Therefore, the widths of the selected bands (frequency spans) have a direct impact on the frequency resolution of the measurements (frequency bins, defined as the distance between two consecutively measured frequency points). As demonstrated in [25], if the frequency bin is larger than the RF bandwidth of the signal being measured, spectrum occupancy may be notably overestimated. On the other hand, occupancy estimation can be reasonably accurate as long as the frequency bin size remains acceptably narrower than the signal RF bandwidth. Frequency spans need therefore to be selected taking into account the RF bandwidth of the signals within the measured band. For example, to measure the bands allocated to the Global System for Mobile communications (GSM), a frequency span of e.g. 45 MHz would be appropriate since it enables the whole band to be measured and results in a frequency bin of $45 \text{ MHz}/(551-1) = 81.8 \text{ kHz}$, which is noticeably narrower than the GSM signal RF bandwidth (200 kHz). Similarly, a frequency span of 400 MHz would result in a frequency bin of 727.3 kHz, which is appropriate to measure, for example, the TeleVision (TV) bands (8 MHz RF bandwidth) and the Universal Mobile Telecommunications System (UMTS) bands (5 MHz RF bandwidth). As shown in Table 1, selecting frequency spans no wider than 600 MHz is sufficient to embrace the widest allocated bands (e.g., TV) and results in frequency bins no greater than 1090.9 kHz, which is also adequate for reliably monitoring the spectral activity of the channels within such bands.

The Resolution BandWidth (RBW) also plays an important role in the reliability of the obtained measurements. Narrowing the RBW increases the ability to resolve signals in frequency and reduces the noise floor (improving the sensitivity) at the cost of an increased sweep time and hence a poorer time resolution [24]. Based on the conclusions from the study carried out in [25], a 10-kHz RBW

Table 1. Spectrum analyzer configuration.

	Parameter	Value	
Frequency	Frequency range	75–3000 MHz	3000–7000 MHz
	Frequency span	< 600 MHz	
	Frequency bin	< 1090.9 kHz	
	Resolution bandwidth	10 kHz	
	Video bandwidth	10 kHz	
Time	Measurement period	1 hour / 24 hours / 7 days	
	Sweep time	Automatically selected	
Amplitude	Detection type	Average (RMS) detector	
	Built-in pre-amplifier	Deactivated	Activated
	Reference level	–20 dBm	–50 dBm
	Scale	10 dB/division	

can be selected as an adequate trade-off between the detection capabilities in the time and frequency dimensions. The Video BandWidth (VBW) is a function that dates to analog spectrum analyzers and can be used to reduce the effect of the noise on the displayed signal amplitude. When the VBW is narrower than the RBW, this filtering has the effect of reducing the peak-to-peak variations of the displayed signal, thus averaging noise without affecting any part of the trace that is already smooth (for example, a signal that is displayed well above the noise level). With modern digital spectrum analyzers this smoothing effect can be achieved by means of trace averaging or, alternatively, by averaging traces off-line (in software) as a part of data post-processing. To eliminate this analog form of averaging, the VBW is set equal to the RBW.

The measurement periods shown in Table 1 are provided as illustrative examples. When the transmitters present in the spectrum band under study are known to be characterized by constant occupancy patterns, measurement periods of 1 hour (even shorter) may be enough to reliably estimate the usage level of the band. This is the case, for example, of TV bands, where the transmission power is constant and the signals are broadcasted all the time in those channels that are actually used. To measure bands with time-varying occupancy patterns, such as those allocated to cellular mobile communication systems, longer measurement periods of 24 hours may be more appropriate in order to adequately detect spectrum use variations. Measurement periods of 7 days can be appropriate in order to identify different patterns between working days and weekends. The number of traces/sweeps recorder within the selected measurement period is a function of the sampling rate (i.e., the sweep time), which is automatically adjusted. Although spectrum analyzers allow the manual selection of the sweep time, it is advisable to permit the automatic configuration of this parameter since it is normally adjusted to the fastest value that enables reliable results.

The power levels for each frequency bin are obtained by means of an average detection principle. This detector averages the power levels observed within one frequency bin in order to provide a representative power level for each frequency bin. As mentioned in section 4, the internal pre-amplifier is deactivated for measurements below 3 GHz since this region of the spectrum is highly populated [8,9], often by high-power transmitters that may cause overloading problems. For spectrum bands above 3 GHz, spectrum is used more sparsely and the more intense signal attenuation caused by these higher frequencies results in the reception of lower power levels. In this case, both the external and the spectrum analyzer's internal amplifiers are employed to provide more reliable measurement results. The reference level (maximum received power that can be measured accurately) in both portions of spectrum is selected according to the maximum powers observed in practice. The amplitude scale is then adjusted to appreciate the minimum signal level that can be detected, which is determined by the spectrum analyzer noise floor and is approximately equal to -110 dBm for the selected RBW when the internal amplifier is deactivated. This sensitivity level, however, is referred to the spectrum analyzer's antenna connector. Taking into account the gains of the internal (≈ 25 dB) and external (≈ 10 dB) amplifiers, the overall sensitivity that can be reached is around -130 dBm/10 kHz, which is enough for a reliable estimation of the true spectrum occupancy.

6 Control Subsystem

The control subsystem, shown in Figure 3, is in charge of supervising the measurement process, retrieving the measurement data from the spectrum analyzer and saving the results in an appropriate format for off-line data post-processing.

The control subsystem is mainly composed of a laptop, which is connected to the spectrum analyzer via an Ethernet interface. The laptop runs a tailor-made script under Matlab's software environment, which controls the measurement process. The control script communicates with the spectrum analyzer by means of the Matlab's Instrument Control Toolbox and making use of commands in SCPI (Standard Commands for Programmable Instruments) format with the VISA (Virtual Instrument Standard Architecture)-TCP/IP interface.

The script receives the following data as input parameters from the user:

- *ip_address*: The IP address configured in the spectrum analyzer.
- *f_start*: The lowest frequency in MHz of the band/span to be measured.
- *f_stop*: The highest frequency in MHz of the band/span to be measured.
- *t_start*: The time instant to begin measurements, specified in year-month-day-hour-minute-second (YYYY/MM/DD/HH/MM/SS) format.
- *t_stop*: The time instant to end measurements, specified in year-month-day-hour-minute-second (YYYY/MM/DD/HH/MM/SS) format.
- *file_name*: The root/base name for the generated data files.
- *nof_traces_per_file*: Number of traces/sweeps saved in each generated file. To avoid excessively large (computationally intractable) files when the measurement period is long (e.g., hours or days), the data are split into several files.

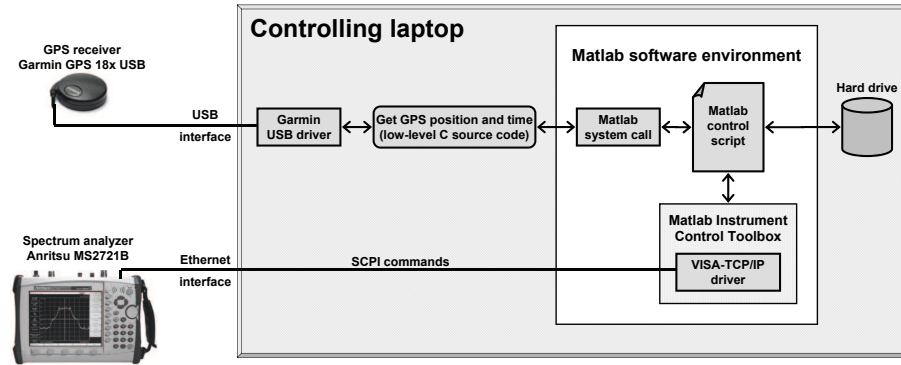

Fig. 3. Control subsystem.

Based on the received input information, the measurement process is controlled as follows (see Algorithm 1). First of all, the script tries to establish communication with the spectrum analyzer at the specified IP address (line 1) by sending the appropriate commands [26]. If the connection establishment is successful, the set of configuration parameters (including the specified frequency band to be measured, the parameters shown in Table 1 and some others) are then sent to the spectrum analyzer (line 2). After initializing the counters and variables employed in the measurement process (lines 3–7), the script then waits until the time for beginning the measurement session is reached (lines 8–10). When the start time is reached, the measurement process begins and it is performed repeatedly until the specified stop time is reached (lines 11–30). Every cycle consists in the realization of one sweep and its storage. The current time at the beginning of the cycle is stored and used as a time stamp for the current sweep (line 12). A new sweep is then immediately commanded to the spectrum analyzer (line 13). The script then waits for the sweep to be complete by continuously monitoring the corresponding status bits of the spectrum analyzer (lines 14–16). When the sweep is complete, the measured data are retrieved (line 17). After removing headers, the measured power values are extracted from the data provided by the spectrum analyzer in comma-separated ASCII format (line 18). The measured power values (line 19) along with the corresponding times tamp (line 20) are concatenated to the appropriate matrices. Since one sweep is completed at this time, the trace counter is increased (line 21) and compared to the number of traces to be saved in each generated file (line 22). In case that a new file needs to be created, the file counter is updated (line 23) and the matrices containing the measured power values (line 24) and their corresponding time stamps (line 25) are then saved, after which the counter and the matrices are reset (lines 26–28). When one cycle (lines 11–30) is finished, another one is started immediately, and the process is repeated cyclically until the stop time is reached. The set of remaining traces/sweeps at this time, lower than *nof_traces_per_file*, is

saved into new files (lines 32–34) along with the frequency vector containing the exact values for the frequency points that have been measured within the band of interest (line 36). The communication with the spectrum analyzer is finally closed (line 37) and the measurement session is finished.

Algorithm 1 Control script

Input: $ip_address, f_start, f_stop, t_start, t_stop, file_name, nof_traces_per_file$
Output: $power_file, time_file, frequency_file$

```

1: Establish communication with the spectrum analyzer  $\rightarrow ip\_address$ 
2: Send configuration to the spectrum analyzer  $\rightarrow ip\_address$ 
   {Including  $f\_start, f\_stop$ , Table 1 and others}
3:  $file\_counter \leftarrow 0$ 
4:  $trace\_counter \leftarrow 0$ 
5:  $power\_matrix \leftarrow []$  {Empty}
6:  $time\_matrix \leftarrow []$  {Empty}
7:  $frequency\_vector \leftarrow$  Set of 551 frequency points between  $f\_start$  and  $f\_stop$ 
8: while  $current\_time < t\_start$  do
9:   Nothing {Wait for  $t\_start$ }
10: end while
11: while  $current\_time < t\_stop$  do
12:    $t \leftarrow current\_time$ 
13:   Initiate new sweep  $\rightarrow ip\_address$ 
14:   while Performing sweep  $\leftarrow ip\_address$  do
15:     Nothing {Wait for the sweep to be completed}
16:   end while
17:   Retrieve sweep data  $\leftarrow ip\_address$ 
18:    $power\_values \leftarrow$  Retrieved sweep data
19:    $power\_matrix \leftarrow [power\_matrix; power\_values]$ 
20:    $time\_matrix \leftarrow [time\_matrix; t]$ 
21:    $trace\_counter \leftarrow trace\_counter + 1$ 
22:   if  $trace\_counter == nof\_traces\_per\_file$  then
23:      $file\_counter \leftarrow file\_counter + 1$ 
24:     Save file  $power\_file(file\_counter) \leftarrow power\_matrix$ 
25:     Save file  $time\_file(file\_counter) \leftarrow time\_matrix$ 
26:      $trace\_counter \leftarrow 0$ 
27:      $power\_matrix \leftarrow []$  {Empty}
28:      $time\_matrix \leftarrow []$  {Empty}
29:   end if
30: end while
31: if  $trace\_counter > 0$  then
32:    $file\_counter \leftarrow file\_counter + 1$ 
33:   Save file  $power\_file(file\_counter) \leftarrow power\_matrix$ 
34:   Save file  $time\_file(file\_counter) \leftarrow time\_matrix$ 
35: end if
36: Save file  $frequency\_file \leftarrow frequency\_vector$ 
37: Close communication with the spectrum analyzer  $\rightarrow ip\_address$ 

```

The time reference employed to determine the beginning and the ending of the measurement session, as well as the time stamps, is obtained from the laptop's internal clock. Alternatively, the time reference can be obtained from an external GPS receiver. This option is useful when two or more measurement suites are deployed at different locations and need to be synchronized among them. In this case, the control script is slightly different: a new cycle (lines 11–30) is not immediately started after the previous one is finished, and an additional input parameter indicating the time period between two consecutive sweeping cycles needs to be specified by the user. The specified time period must be long enough to allow for a complete cycle to be performed, and enables various measurement suites to be synchronized on a sweep basis. This kind of measurements is interesting, for example, for determining how several nodes of a DSA/CR network at different locations perceive the spectral activity of the same primary transmitter, and for identifying potential correlation patterns. Additionally, the external GPS receiver can be used to easily determine the location where the measurement is being performed, and establish correlation patterns as a function of the distance between DSA/CR nodes. This operation mode may find other interesting applications as well.

The device employed in the presented implementation (Garmin GPS 18x USB) is a small and highly accurate GPS receiver with high sensitivity levels (−184 dBW) and a maximum acquisition time of around 45 seconds. As shown in Figure 3, the GPS receiver requires a specific USB driver to be installed in the controlling laptop. This driver is used by a set of three executable files, written in C source code, containing a low-level implementation of the proprietary Garmin USB communication protocol [27]. Each file executes a different set of commands, depending on its finality. The first file checks the connectivity with the GPS receiver to verify that it is properly connected and working. The other two files retrieve the current GPS location and current GPS time, respectively, from the GPS receiver. These files are executed from the operating system's command line, and invoked from Matlab by means of a system call with the `system` function. Each executable file returns the result of the corresponding operation (i.e., GPS receiver status, GPS location or GPS time) as a character string with a predefined format, which is processed by the control script in order to extract the desired information. While the files providing the GPS receiver status and location are invoked once at the beginning of each measurement session, the GPS time is requested repeatedly in order to obtain the desired time reference.

As shown in Algorithm 1, the control script generates, for each measurement session, one file storing the frequency points measured within the band of interest (*frequency_file*) and a set of files containing the measured power values (*power_file*) and the corresponding time stamps (*time_file*). The *frequency_file* contains a 1×551 row vector including the frequency points, in MHz, that have been measured by the spectrum analyzer. This vector length corresponds to the number of points per sweep provided by the selected spectrum analyzer. Each generated *power_file* contains a *nof_traces_per_file* $\times 551$ matrix whose values correspond to the power level recorded at each one of the 551 measured frequency

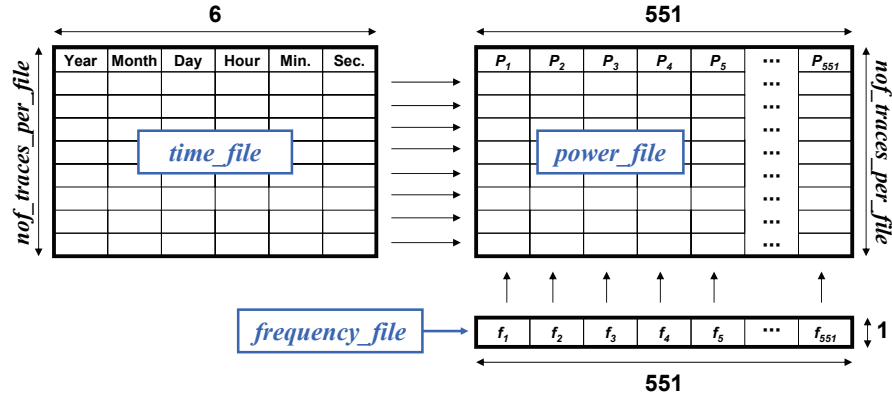

Fig. 4. Data formats.

points for a total amount of *nof_traces_per_file* sweeps. The default unit for expressing the recorded power levels is dBm but it can be modified to represent both power and voltage amplitude values in various orders of magnitude (e.g., mW and W) and either in linear or logarithmic magnitude (e.g., mW and dBm). For each generated *power_file* there exists a corresponding *time_file* containing a $\text{nof_traces_per_file} \times 6$ matrix, where the n -th row contains the time stamp (in YYYY-MM-DD-HH-MM-SS format) for the sweep reported in the n -th row of the associated *power_file*. The data formats for each file and the corresponding relations are illustrated in Figure 4.

Notice that the selected data formats provide some interesting advantages for data storage and data post-processing. On one hand, the *frequency_file* and the *time_file* can be employed to search for the empirical data corresponding to particular time periods and frequency ranges. Since these matrices are significantly small, the files where they are stored can be loaded and processed very fast. This enables particular sets of empirical data of interest to be rapidly found within the set of matrices contained in the *power_file* files, which are of significantly higher sizes. Once the subset of empirical data of interest is identified by exhaustive searching within the corresponding set of *frequency_file* and *time_file* files, only the *power_file* file(s) containing the desired data need to be loaded and processed. Moreover, the size of each *power_file* depends on the value of the parameter *nof_traces_per_file* provided as an input to the control script, which can be flexibly configured depending on the available computational capabilities. For powerful computers able to simultaneously handle very high data volumes, this parameter can be set to higher values, thus reducing the amount of required data files and storage space. In conclusion, the selected data formats enable large volumes of empirical data not only to be stored and structured systematically, but also to be accessed and processed in an easy, fast and efficient manner.

7 Example of Operational Measurements

As mentioned in Section 1, the developed platform has successfully been employed to conduct extensive spectrum occupancy measurement campaigns [8, 9, 21] and empirical studies [22] in the context of DSA/CR. This section presents, as an illustrative example of operational measurements, results of a recent measurement campaign. The campaign evaluated concurrently, with two identical measurement suites, the spectrum occupancy in the frequency range up to 3 GHz observed during a 24-hour period in the UPC's Campus Nord in Barcelona, Spain ($41^{\circ} 23' 20''$ N, $2^{\circ} 6' 43''$ E), which constitutes a densely populated urban environment, and the UPC's Campus in Castelldefels, Spain ($41^{\circ} 16' 31''$ N, $1^{\circ} 59' 13''$ E), which represents a moderately populated suburban environment.

The main obtained results are shown in Figures 5 and 6. Each figure is composed of three graphs. The upper graph shows the measured Power Spectral Density (PSD) in minimum, maximum and average values. The middle graph shows the instantaneous spectrum occupancy during the whole measurement period (black points represent busy samples). The lower graph shows the Duty Cycle (DC) as a function of frequency, which is computed as the percentage of time that each frequency is observed as busy. As it can be appreciated, the overall spectrum occupancy is noticeably higher in the urban environment of Barcelona (average DC of 21.21%) than in the suburban environment of Castelldefels (average DC of 15.15%). In particular, it is interesting to note how the bands allocated to cellular mobile communication systems such as DCS 1800 (1805–1880 MHz) and UMTS (2110–2170 MHz), have more channels in use (and subject to a more intensive usage) in the urban environment. A similar trend is observed in other bands at lower frequencies (below 1 GHz). In some concrete bands such as those allocated to broadcast services, e.g. TV (470–862 MHz) or DAB-T (195–223), where spectrum use does not depend on the number of users of the service, the results are more similar in both environments. Figure 7 shows the utilization of TV channels as observed from the measured locations. As it can be appreciated, most of the channels are observed in the same state in both cities, which can be explained by the fact that the distance between them (≈ 23 km) is shorter than the coverage areas usually intended for TV transmitters and, as a result, both locations observe the same transmitters. An exception is noticed in channels 24, 29, 39, 42, 51 and 57, which may be due to local short-range TV stations.

One particularly appealing feature of the developed platform is its ability to be synchronized with other identical units. As mentioned in Section 6, this feature can be employed to determine and compare the instantaneous spectrum occupancy perception of a given transmitter at different locations, and study any underlying correlation properties. As an example of this type of measurements, Figure 8 shows the time evolution of the DC, computed over 1-hour intervals, for the 108–144 MHz aeronautical band. This band is employed by aircrafts to communicate with the airport's control towers. As it can be appreciated, the level of activity observed in this spectrum band is very similar in both locations and shows a high level of correlation (the correlation coefficient of the DC sequences in Figure 8 is 0.85), which can be explained by the fact that the Airport of

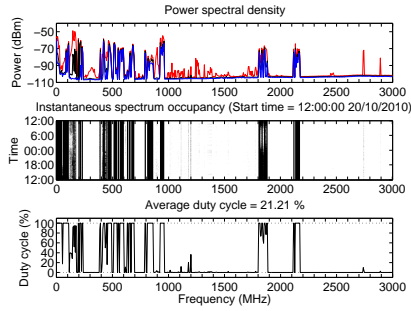

Fig. 5. Spectrum use in Barcelona.

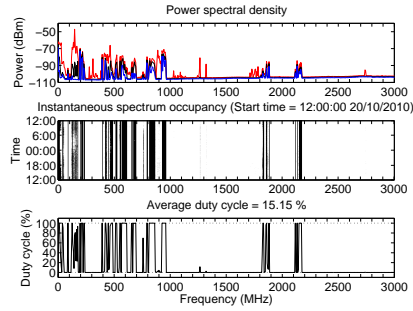

Fig. 6. Spectrum use in Castelldefels.

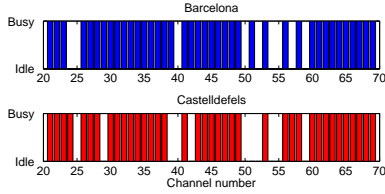

Fig. 7. Utilization of the TV channels in Barcelona and Castelldefels.

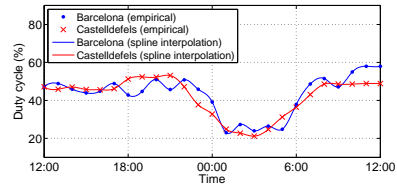

Fig. 8. Time evolution of the duty cycle for the aeronautical band 108–144 MHz.

Barcelona is located between the two considered cities and, as a result, the same radio transmissions are simultaneously observed under line of sight in both measurement locations. This mode of operation of the measurement platform can be employed to simultaneously monitor the spectral activity of a set of transmitters over a higher number of measurement locations and carry out a detailed analysis of spatial correlations. This kind of study, however, is out of the scope of this illustrative section.

8 Conclusion

This paper has presented a sophisticated radio spectrum measurement platform specifically envisaged and designed for spectrum occupancy surveys in the context of the DSA/CR technology. The presented tool is a very flexible system combining a powerful radio measurement design with intelligent computer control and data processing. The developed platform can be employed to carry out extensive spectrum measurement campaigns, with significant sensitivity levels, and providing a set of structured empirical data that can be analyzed and processed in an easy, fast and efficient manner. An exhaustive and in-depth description of the developed measurement platform has been provided, with a special emphasis on implementation details that may result helpful to other researchers and engineers in the development of similar radio spectrum measurement tools.

Acknowledgments

The authors would like to express their gratitude to Dr. Antoni Gelonch for his valuable help and the logistic support provided for the measurements performed in Castelldefels. This work was supported by the European Commission in the framework of the FP7 FARAMIR Project (Ref. ICT-248351) and the Spanish Research Council under research project ARCO (Ref. TEC2010-15198). The support from the Spanish Ministry of Science and Innovation (MICINN) under FPU grant AP2006-848 is hereby acknowledged.

References

1. Matheson, R.J.: A radio spectrum measurement system for frequency management data. *IEEE Transactions on Electromagnetic Compatibility* **EMC-19**(3) (August 1977) 225–230
2. McHenry, M.A., et al.: Spectrum occupancy measurements. Technical report, Shared Spectrum Company (January 2004 - August 2005) Available online at <http://www.sharespectrum.com>.
3. Petrin, A., Steffes, P.G.: Analysis and comparison of spectrum measurements performed in urban and rural areas to determine the total amount of spectrum usage. In: *Proceedings of the International Symposium on Advanced Radio Technologies (ISART 2005)*. (March 2005) 9–12
4. Chiang, R.I.C., Rowe, G.B., Sowerby, K.W.: A quantitative analysis of spectral occupancy measurements for cognitive radio. In: *Proceedings of the IEEE 65th Vehicular Technology Conference (VTC 2007 Spring)*. (April 2007) 3016–3020
5. Wellens, M., Wu, J., Mähönen, P.: Evaluation of spectrum occupancy in indoor and outdoor scenario in the context of cognitive radio. In: *Proceedings of the Second International Conference on Cognitive Radio Oriented Wireless Networks and Communications (CrowCom 2007)*. (August 2007) 1–8
6. Islam, M.H., et al.: Spectrum survey in Singapore: Occupancy measurements and analyses. In: *Proceedings of the 3rd International Conference on Cognitive Radio Oriented Wireless Networks and Communications (CrownCom 2008)*. (May 2008) 1–7
7. Bacchus, R.B., Fertner, A.J., Hood, C.S., Roberson, D.A.: Long-term, wide-band spectral monitoring in support of dynamic spectrum access networks at the IIT spectrum observatory. In: *Proceedings of the 3rd IEEE International Symposium on New Frontiers in Dynamic Spectrum Access Networks (DySPAN 2008)*. (October 2008) 1–10
8. López-Benítez, M., Umbert, A., Casadevall, F.: Evaluation of spectrum occupancy in Spain for cognitive radio applications. In: *Proceedings of the IEEE 69th Vehicular Technology Conference (VTC 2009 Spring)*. (April 2009) 1–5
9. López-Benítez, M., Casadevall, F., Umbert, A., Pérez-Romero, J., Palicot, J., Moy, C., Hachemani, R.: Spectral occupation measurements and blind standard recognition sensor for cognitive radio networks. In: *Proceedings of the 4th International Conference on Cognitive Radio Oriented Wireless Networks and Communications (CrownCom 2009)*. (June 2009) 1–9

10. Pagadarai, S., Wyglinski, A.M.: A quantitative assessment of wireless spectrum measurements for dynamic spectrum access. In: Proceedings of the 4th International Conference on Cognitive Radio Oriented Wireless Networks and Communications (CrownCom 2009). (June 2009) 1–5
11. Qaraqe, K.A., Celebi, H., Gorcin, A., El-Saigh, A., Arslan, H., Alouini, M.: Empirical results for wideband multidimensional spectrum usage. In: Proceedings of the IEEE 20th International Symposium on Personal, Indoor and Mobile Radio Communications (PIMRC 2009). (September 2009) 1262–1266
12. Martian, A., Marcu, I., Marghescu, I.: Spectrum occupancy in an urban environment: A cognitive radio approach. In: Proceedings of the Sixth Advanced International Conference on Telecommunications (AICT 2010). (May 2010) 25–29
13. Schiphorst, R., Slump, C.H.: Evaluation of spectrum occupancy in Amsterdam using mobile monitoring vehicles. In: Proceedings of the IEEE 71st Vehicular Technology Conference (VTC Spring 2010). (May 2010) 1–5
14. Valenta, V., Maršálek, R., Baudoin, G., Villegas, M., Suarez, M., Robert, F.: Survey on spectrum utilization in Europe: Measurements, analyses and observations. In: Proceedings of the Fifth International Conference on Cognitive Radio Oriented Wireless Networks & Communications (CrownCom 2010). (June 2010) 1–5
15. Jackson, C.: Dynamic sharing of radio spectrum: A brief history. In: Proceedings of the First IEEE International Symposium on New Frontiers in Dynamic Spectrum Access Networks (DySPAN 2005). (November 2005) 445–466
16. Zhao, Q., Sadler, B.M.: A survey of dynamic spectrum access. *IEEE Signal Processing Magazine* **24**(3) (May 2007) 78–89
17. Buddhikot, M.M.: Understanding dynamic spectrum access: Taxonomy, models and challenges. In: Proceedings of the 2nd IEEE International Symposium on New Frontiers in Dynamic Spectrum Access Networks (DySPAN 2007). (April 2007) 649–663
18. Akyildiz, I.F., Lee, W.Y., Vuran, M.C., Mohanty, S.: NeXt generation/dynamic spectrum access/cognitive radio wireless networks: A survey. *Computer Networks* **50**(13) (September 2006) 2127–2159
19. Mitola, J., Maguire, G.Q.: Cognitive radio: making software radios more personal. *IEEE Personal Communications* **6**(4) (August 1999) 13–18
20. Haykin, S.: Cognitive radio: Brain-empowered wireless communications. *IEEE Journal on Selected Areas in Communications* **23**(2) (February 2005) 201–220
21. López-Benítez, M., Casadevall, F.: On the spectrum occupancy perception of cognitive radio terminals in realistic scenarios. In: Proceedings of the 2nd IAPR International Workshop on Cognitive Information Processing (CIP 2010). (June 2010) 99–104
22. López-Benítez, M., Casadevall, F.: Spatial duty cycle model for cognitive radio. In: Proceedings of the 21st Annual IEEE International Symposium on Personal, Indoor and Mobile Radio Communications (PIMRC 2010). (September 2010) 1629–1634
23. Egan, W.F.: Practical RF system design. Wiley-IEEE Press (2003)
24. Agilent: Application note 150: Spectrum analysis basics. Available online at <http://www.agilent.com>.
25. López-Benítez, M., Casadevall, F.: Methodological aspects of spectrum occupancy evaluation in the context of cognitive radio. *European Transactions on Telecommunications* **21**(8) (December 2010) 680–693
26. Anritsu: Programming manual for MS272XB series spectrum analyzers. (January 2007) Available online at <http://www.anritsu.com>.
27. Garmin: Garmin Device Interface Specification. (May 2006) Available online at <http://www.garmin.com>.